

KG=KAPI GENİŞLİĞİ
X max = 0,75 * KG

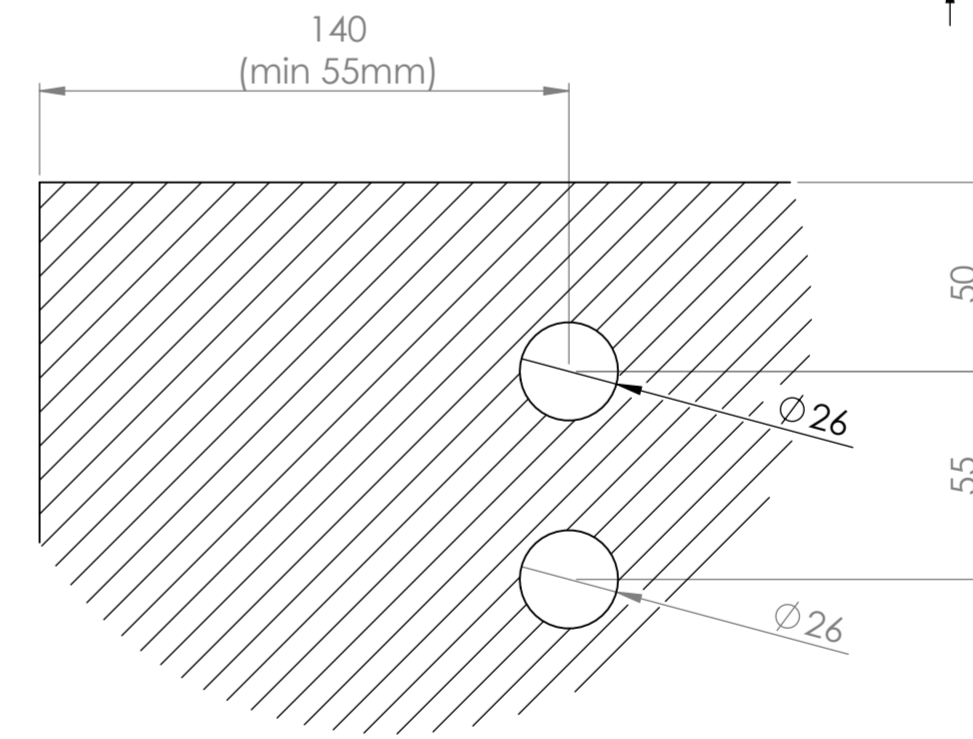

CAM KEŞİDİ
HAREKETLİ CAM

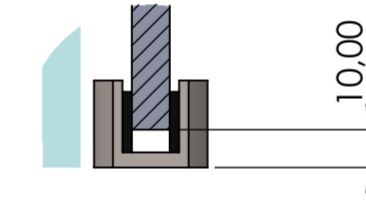
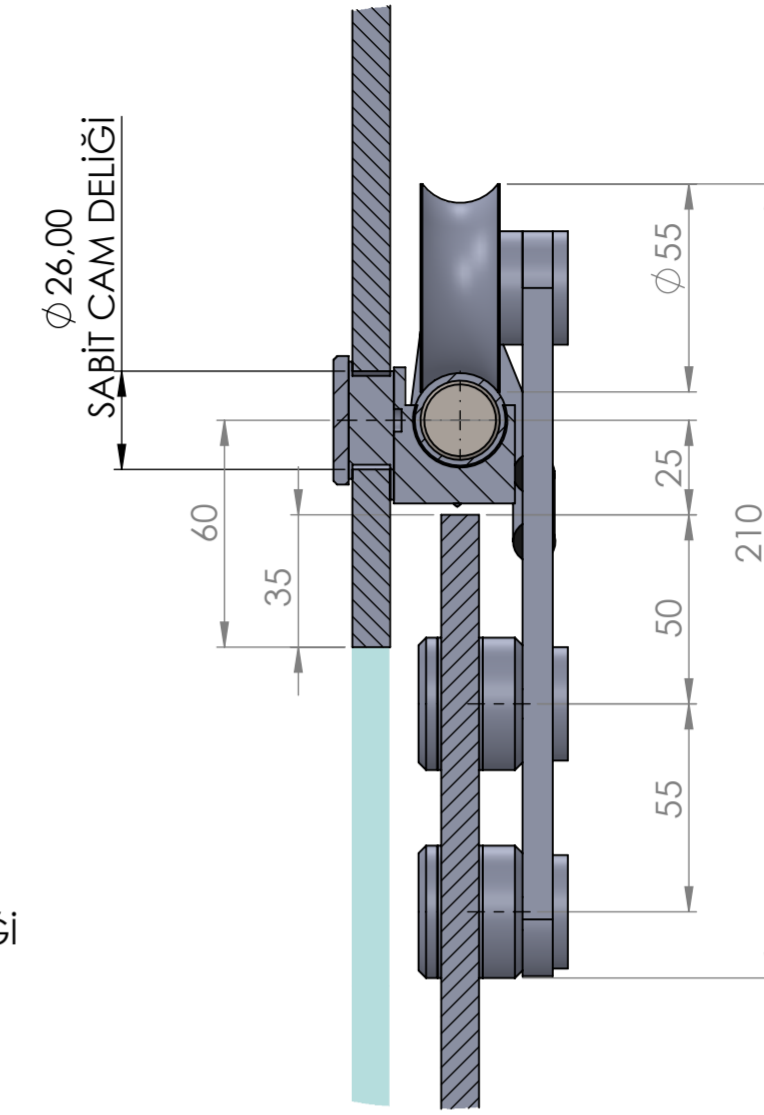

**HATİPOĞLU
CAM AKSESUARLARI**

ÜRÜN KODU	THR - 8101 CAM	ÖLÇEK	1:10
REV. TARİHİ / NO	20-06-2022	SAYFA BOYUTU	A2
TİCARİ ÜNVAN	HATİPOĞLU HIRDAVAT SAN. VE TİC. LTD. ŞTİ.		

Resimler üzerinde verilen boyutlarda ve ölçülendirmelerde olacak değişikliklerden ve bu değişikliklerin sebep olacağı sorunlardan Hatipoğlu Hırdavat San. ve Tic. Ltd. Şti. sorumlu tutulamaz.

We are not responsible as Hatipoğlu Hırdavat San. ve Tic. Ltd. Şti. on any kind of problem caused by the changes of dimensions